

# POINT-OF-SALE CAMERA ARM

## FEATURES

- Easy to install, with no lift required
- Universal design accommodates several point-of-sale form factors and layouts
- Precise camera positioning provides industry-leading analytic capabilities
- Accommodates a wide range of cameras from various manufacturers
- Facilitates repeatable installations and deployments for scalable project roll outs



## MODELS

**PSAF-CLM-S-UCB1-D** Point-of-Sale Camera Armature, Cabinet Mount, Short Reach, Universal Camera Bracket (*Camera Not Included*)

## DIMENSIONS

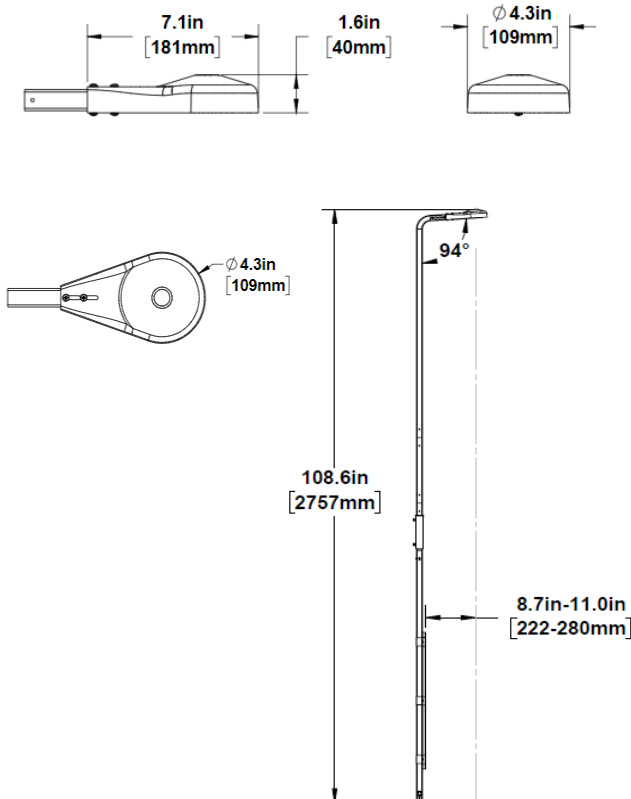

MODEL NUMBER	PSAF-CLM-S-UCB1-D
<b>CONSTRUCTION</b>	
PSAF ARMATURE	
Material	Steel
Finish	Powder Coat
Color	Gray
<b>MOUNTING BRACKETS</b>	
Material	Steel
Finish	Powder Coat
Color	Gray
<b>CAMERA ENCLOSURE</b>	
Material	Polystyrene
Color	Black
<b>PHYSICAL</b>	
Environment	Indoor
Product Dimensions	108.6"x(8.7-11.0)"
Product Weight	12.30 lbs
Shipping Dimensions	46.875"L x 6.25"W x 6.5"D
Shipping Weight	14.15 lbs