

UNIVERSAL GONDOLA MOUNT INSTALLATION INSTRUCTIONS

Model# MM-PVM08GUX-W



The Power to See
Your BusinessSM

Customize Mounting Pieces

- Due to various Gondola Heights and Shelving Widths cutting of the Horizontal and Vertical Mounting Pieces may be required.
- To help with this customization, predefined cut marks (dimples) are on each piece.
- If cutting of the Vertical piece is needed you will first have to remove it from the Bent Tube.
- Please refer to some examples below. See Fig. 1.

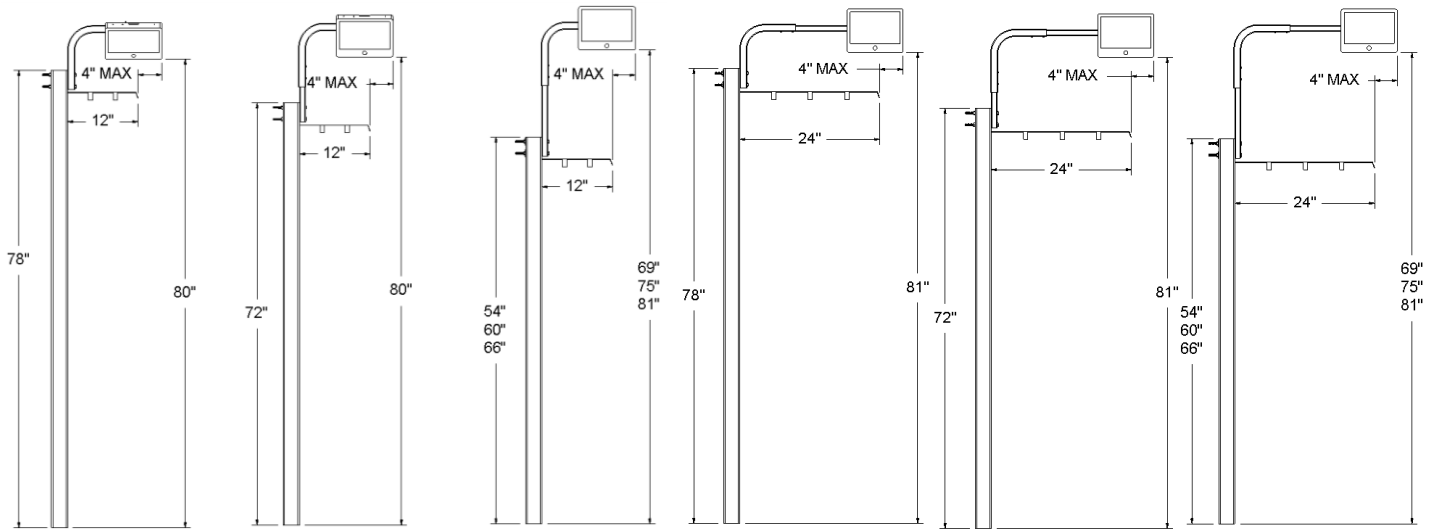

Fig. 1. Custom Mounting Options

Mount Assembly

- After the customization is complete.
- Align Bent Tube and Horizontal Mounting Pieces. See Fig. 2.
- Slide 1 inch Horizontal Tube into 1.25 inch Bent Tube; fasten using (2) #10-32 Phillips Screws. See Fig. 3.
- Complete Assembled Mount. See Fig. 4.

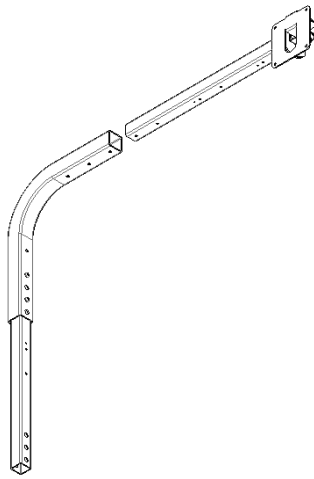

Fig. 2. Align Mounting Pieces

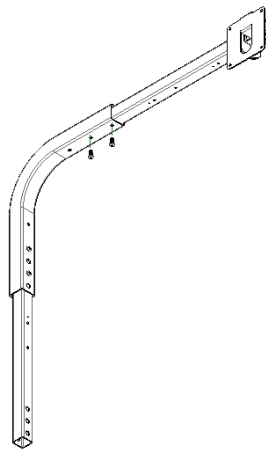

Fig. 3. Mount Assembly

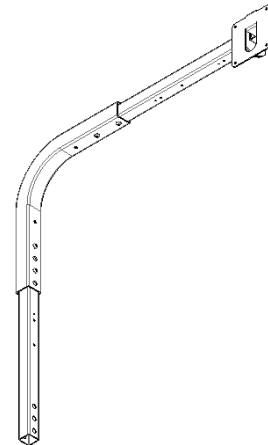

Fig. 4. Completed Assembly Mount

Mounting to Gondola Upright

- Hold Vertical Tube so that both bolt holes align with top of Gondola Upright slots.
- Fasten Assembled Mount to Gondola Upright using (2) 5/16-18 Hex Head Bolt. See Fig. 5.
- Complete Gondola Mounting. See Fig. 6.

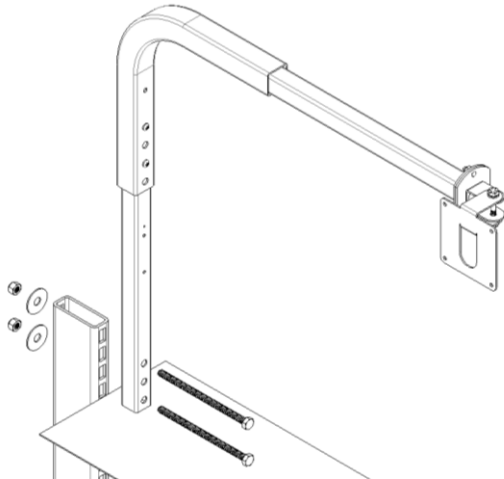

Fig. 5. Mount to Gondola

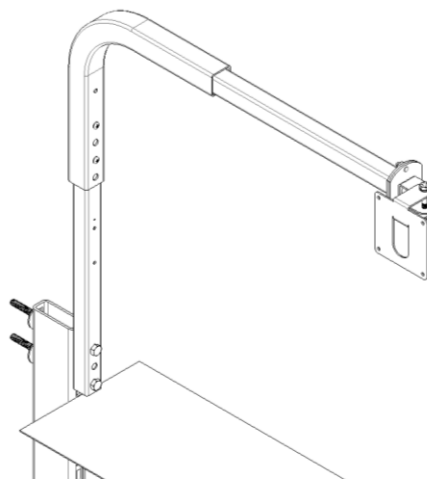

Fig. 6. Complete Gondola Mounting

Tyco Monitor Mounting

- Attach the ePVM to the VESA plate using (3) M4 screws. See Fig. 7.
- Complete Install. See Fig. 8.

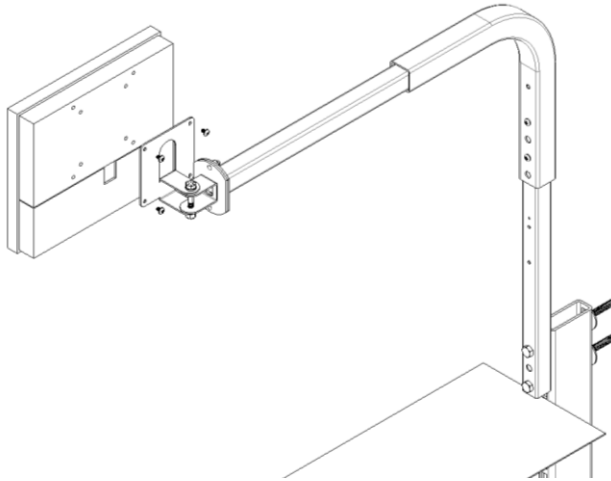

Fig. 7. ePVM to the VESA plate

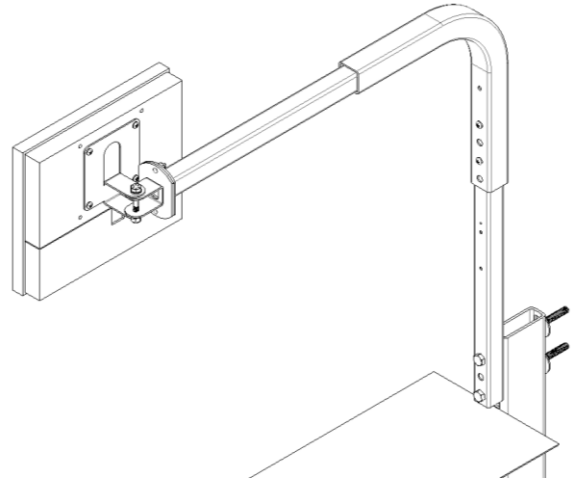

Fig. 8. Complete Install

Cable Protection Kit

- Feed monitor power cable through flex conduit until approximately 4" of cable is exposed. See Fig. 9.
- Insert cable leads into monitor power terminal block. See Fig. 10.
- Slide strain relief plate into the slot in back of the monitor. See Fig. 11.
- Put cable clip around flex conduit and fasten to VESA plate using remaining M4 screw. See Fig. 12.
- Slide flex conduit inside horizontal mounting tube and use (1) zip tie to fasten flex conduit to mounting plate. See Fig. 13.



Fig. 9. Power Cable Thru Conduit



Fig. 10. Power to Terminal Block



Fig. 11. Strain Relief Plate



Fig. 12. Cable Clip



Fig. 13. Zip Tie

Wren Monitor Mounting

- Attach the ePVM to the VESA plate using (4) M4 screws. See Fig. 14.
- Complete Install. See Fig. 15.

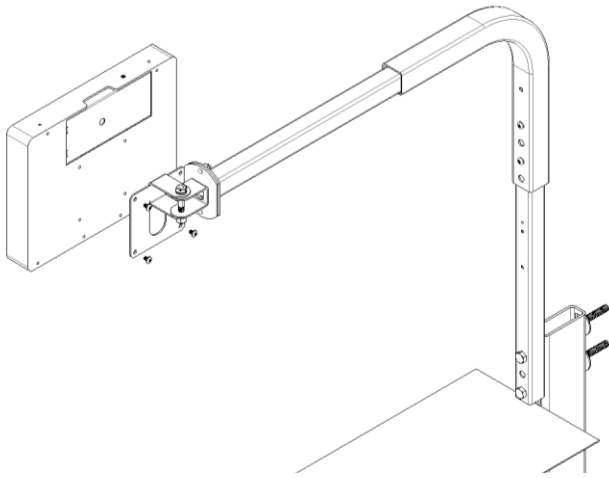

Fig. 14. ePVM to the VESA plate

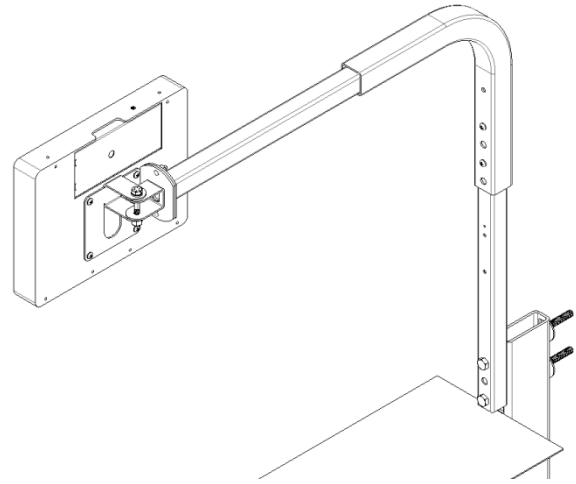

Fig. 15. Complete Install